

---

Overview .....	8
150 lb. valves .....	9
300 lb. valves .....	9
600 lb. valves .....	10
900 lb. valves .....	10
1500 lb. valves .....	10
2500 lb. valves .....	10

---

# GATE VALVES

---

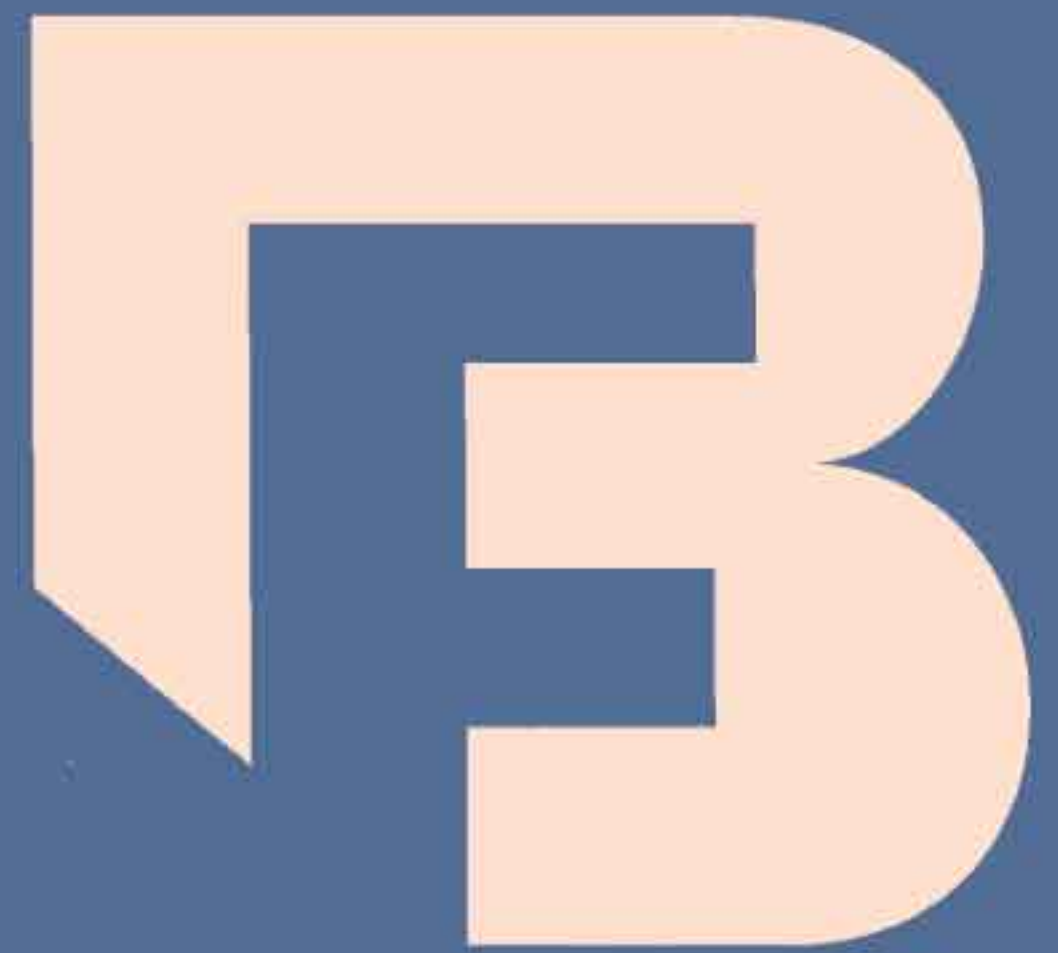

## GATE VALVES

Cast Steel, outside screw and yoke, rising stem, non-rising hand-wheel, removable yoke sleeve.

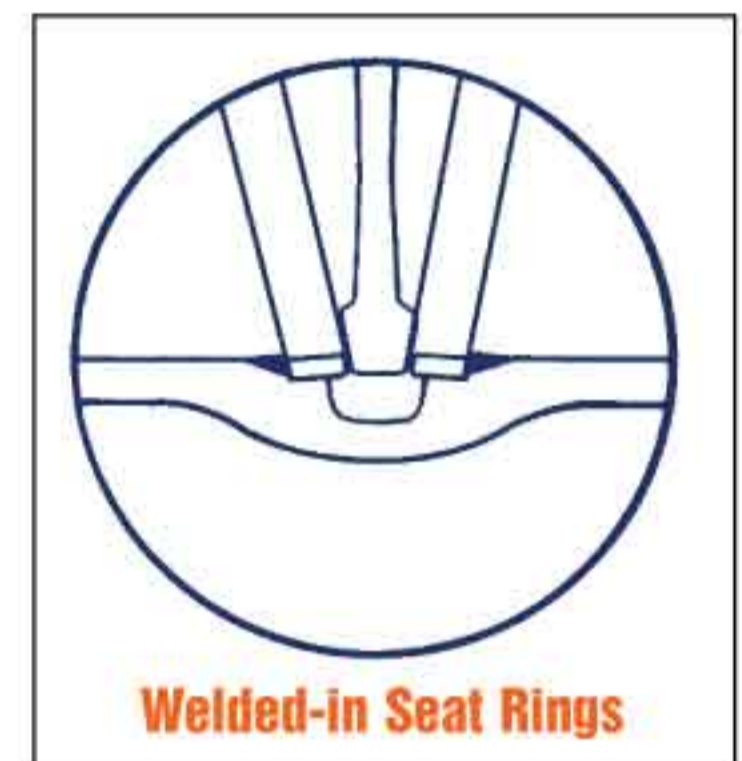
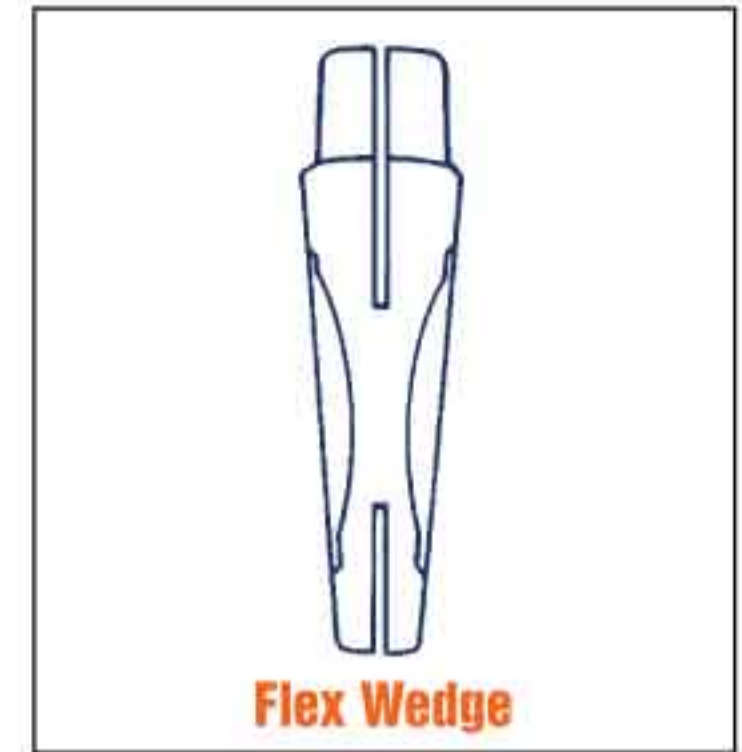
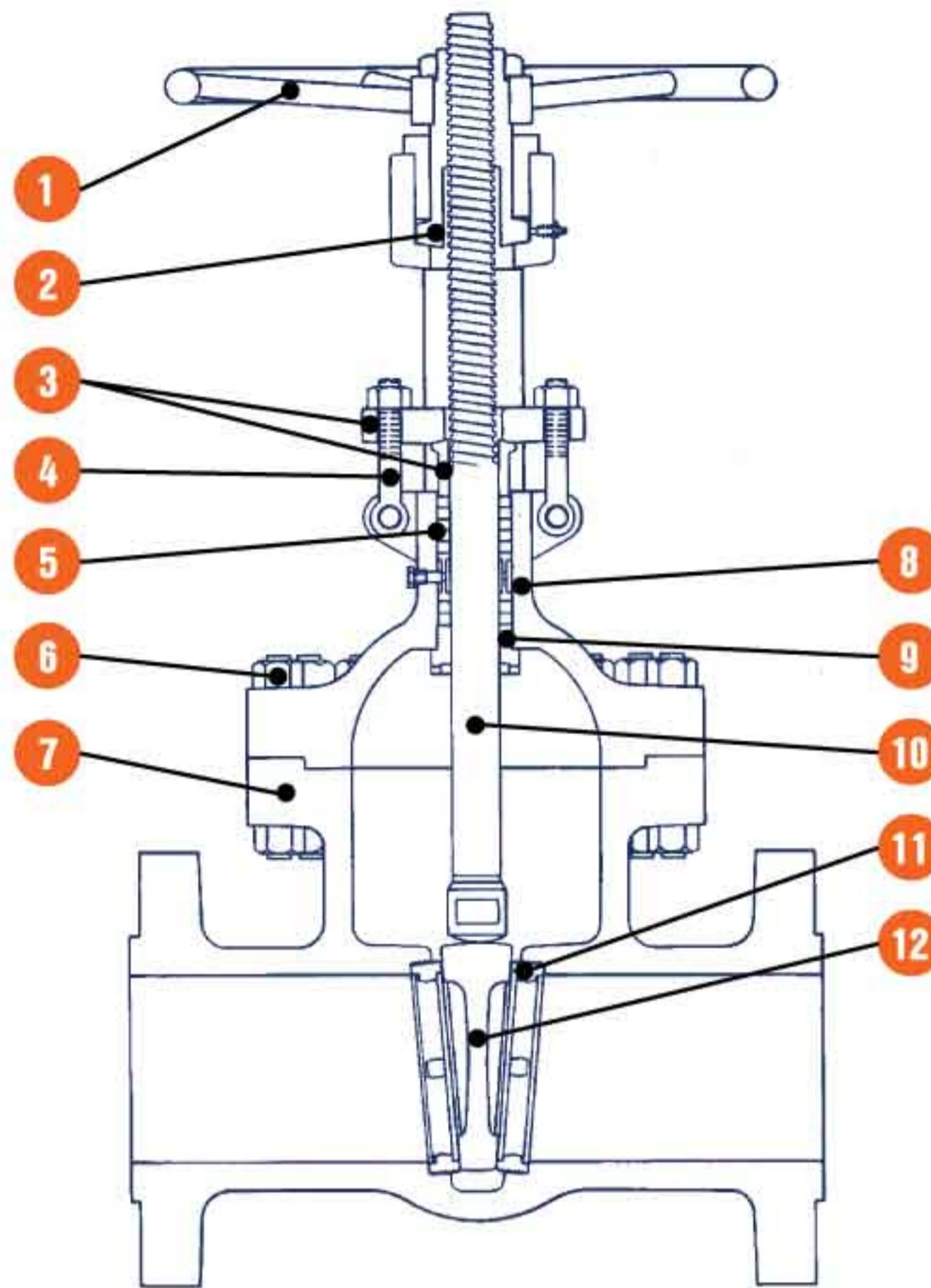

1. **HANDWHEEL.** The five-spoked handwheel is fabricated from steel pipe. The hub has a hexagonal taper for coupling to the yoke sleeve.
2. **YOKE SLEEVE.** The yoke sleeve is made from cast Iron Ni resist D2 having high resistance to wear and a high melting point, about 2000° F. It is designed to permit removal from the bonnet or the yoke while the valve is in service. Gate valves 6" 600 lb. Class and above are fitted with ball thrust bearing.
3. **GLAND AND FLANGE.** They are forged steel and are supplied in two pieces. The contact surfaces between gland and gland flange have a spherical profile to permit the gland to descend parallel to the stem even if the eyebolts are unevenly tightened.
4. **GLAND BOLTS AND NUTS.** The forged steel gland bolts are of the eyebolt type which can be swung outward for ease of gland repacking. They are fixed to the bonnet by stud bolts and nuts.
5. **LANTERN.** Lantern rings are available upon request.
6. **BONNET BOLTING.** Bonnet studs and nuts are manufactured from alloy steel to the relevant ASTM standard.
7. **BODY.** The body is in cast steel and is carefully designed in all its details. The basic dimensions, i.e. wall thickness, face to face and flanges comply with the relevant API and ANSI standards. The body-to-bonnet flange is normally circular, except in the 150 lb. Class which is oval. The sealing surfaces for connection to the bonnet are flat finish in the 150 lb. Class, recessed in the 300 lb. Class and ring joint in the 600 lb. Class and above. Bosses are provided for drain taps or by-pass piping.
8. **BONNET.** The bonnet is in cast steel. It is machined to accept the yoke sleeve and incorporates a stuffing box dimensioned in accordance with the API standard.
9. **BONNET BUSHING.** The bonnet bushing or backseat is in forged stainless steel and forms part of the trim. Special attention is given both to its machining and heat treatment.
10. **STEM.** The stem is in forged stainless steel and is part of the trim. The stem is provided with a T head. A ground backseat is provided to ensure a perfectly tight seal to the stuffing box when the valve is fully open. The stem is ground to minimize friction and prevent damage to gland packing. The threading is trapezoidal ACME type. Dimensions comply with the API 600 standard.
11. **SEAT RINGS.** The rings are forged stainless steel and are part of the trim. They are seal welded in place. Special attention is given to the sealing surfaces which are ground and lapped for a perfect seal. Threaded-in seat rings may be supplied upon request.
12. **WEDGE.** The wedge is part of the trim. It is forged stainless steel for diameters up to 6" and in cast steel for larger valves. It is normally supplied as the flexible wedge type. It is connected to the stem by means of a T joint. The guides on each side of the wedge are machined. Special attention is given to the seating surfaces which are ground and lapped.

**150 LB.**  
**300 LB.**

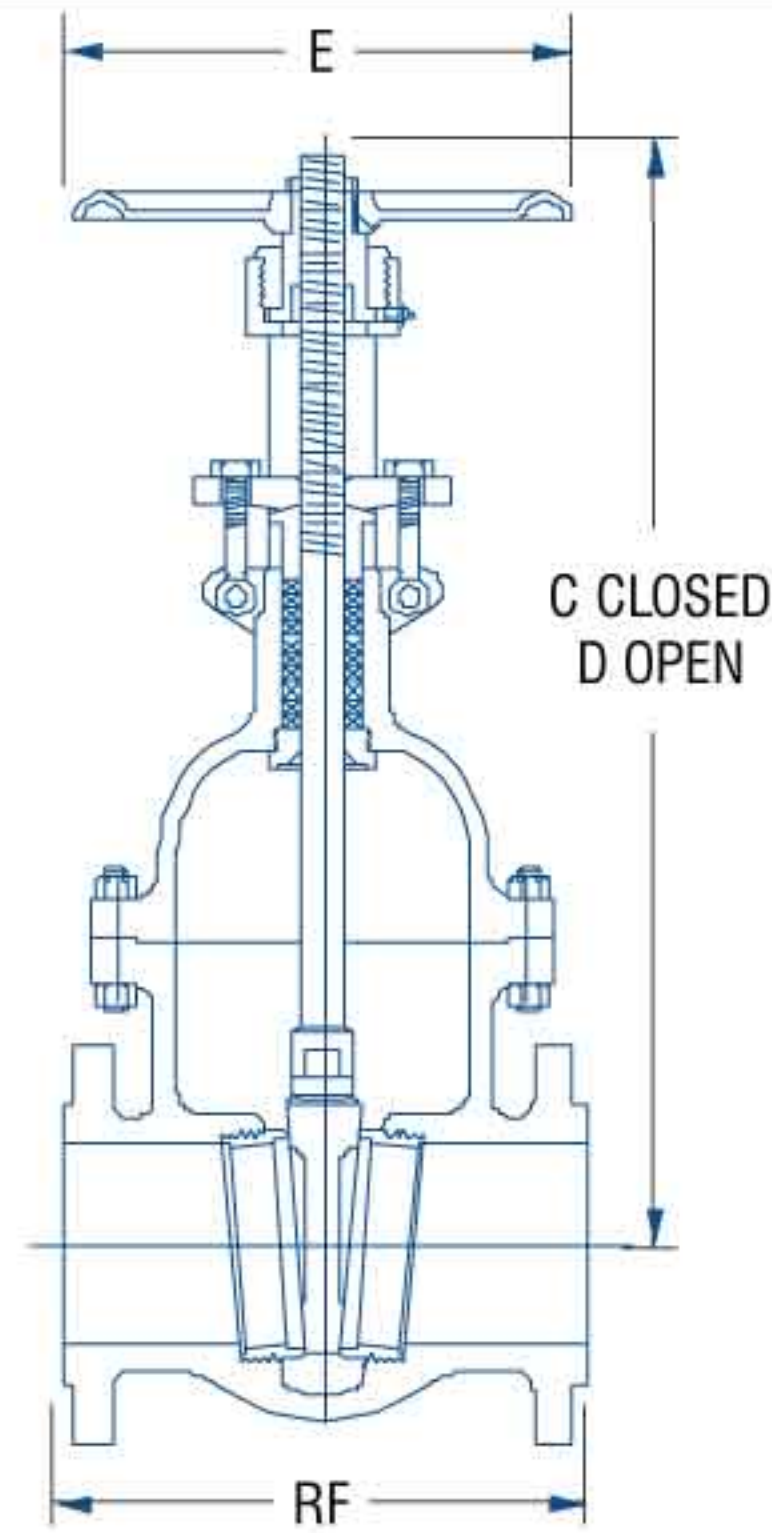

**VALVE DIMENSIONS AND WEIGHTS**

		2"	2.5"	3"	4"	6"	8"	10"	12"	14"	16"	18"	
<b>150 LB.</b>	End to End <b>RF</b>	7.0	7.5	8.0	9.0	10.5	11.5	13.0	14.0	15.0	16.0	17.0	
	End to End <b>BW</b>	8.5	9.5	11.125	12.0	15.875	16.5	18.0	19.75	22.5	24.0	26.0	
	<b>C</b> - Closed	15.23	16.3	18.42	22.44	26.77	33.26	38.6	44.1	52.36	56.9	64.17	
	<b>D</b> - Open	17.79	19.3	21.97	27.12	33.37	42.06	49.8	56.77	66.8	73.35	82.07	
	<b>E</b>	9.85	8.0	11.81	11.81	15.75	19.7	23.62	23.62	31.5	31.5	43.3	
	<b>WEIGHTS</b>	<b>RF</b>	57.32	66.14	77.16	121.2	183.0	328.5	522.5	668.0	963.4	1155	1479
		<b>BW</b>	48.5	52.91	68.34	101.4	167.5	310.9	493.8	646.0	917.1	1010	1452
			20"	24"	26"	28"	30"	32"	34"	36"	40"	42"	48"
	<b>150 LB.</b>	End to End <b>RF</b>	18.0	20.0	22.0	24.0	24.0	26.0	28.0	28.0	32.0	32.0	34.0
		End to End <b>BW</b>	28.0	32.0	34.0	36.0	36.0	38.0	40.0	40.0	46.0	55.0	50.0
<b>C</b> - Closed		72	83.5	90	103.7	102	115.7	105.9	130	138.2	150.4	160	
<b>D</b> - Open		92	107.85	115.6	133.6	131.1	148	140.0	166	178.7	190.16	208	
<b>E</b>		43.3	78.7	78.7	78.7	78.7	78.7	36.0	78.7	78.7	78.7	36.0	
<b>WEIGHTS</b>	<b>RF</b>	1907	2910	3327	4524	5320	5291	6043	7011	10785	10939	14330	
	<b>BW</b>	1880	2857	3054	-	5095	5115	5875	6548	-	9682	-	
		2"	2.5"	3"	4"	6"	8"	10"	12"				
<b>300 LB.</b>	End to End <b>RF-BW</b>	8.5	9.5	11.125	12.0	15.875	16.5	18.0	19.75				
	End to End <b>RTJ</b>	9.125	10.125	11.75	12.625	16.5	17.125	18.625	20.375				
	<b>C</b> - Closed	15.23	16.9	18.3	22.44	29.52	34.25	39.37	46.88				
	<b>D</b> - Open	17.73	20.1	21.8	27.04	36.09	43.03	49.37	59.38				
	<b>E</b>	9.85	8.0	11.81	15.75	19.7	23.62	23.62	31.5				
	<b>WEIGHTS</b>	<b>RF</b>	63.93	90.39	123.4	180.8	363.8	579.8	855.4	1212			
		<b>BW</b>	50.7	70.55	96.75	138.9	313.1	553.3	751.8	977.8			
			14"	16"	18"	20"	24"	30"	36"	42"			
	<b>300 LB.</b>	End to End <b>RF-BW</b>	30.0	33.0	36.0	39.0	45.0	55.0	68.0	78.0			
		End to End <b>RTJ</b>	30.625	33.625	36.625	39.75	45.875	56.0	69.125	79.0			
<b>C</b> - Closed		53.9	62	69.7	77.9	82	115.3	129.1	136.0				
<b>D</b> - Open		67.68	78.53	87.5	98.76	105.9	145.6	165.5	177.6				
<b>E</b>		31.5	43.3	43.3	78.7	78.7	78.7	78.7	36.0				
<b>WEIGHTS</b>	<b>RF</b>	1764	2350	3137	5952	5974	10626	15785	18078				
	<b>BW</b>	1478	2034	2777	5480	5284	9458	14110	16347				

**600 LB.**

**1500 LB.**

**900 LB.**

**2500 LB.**

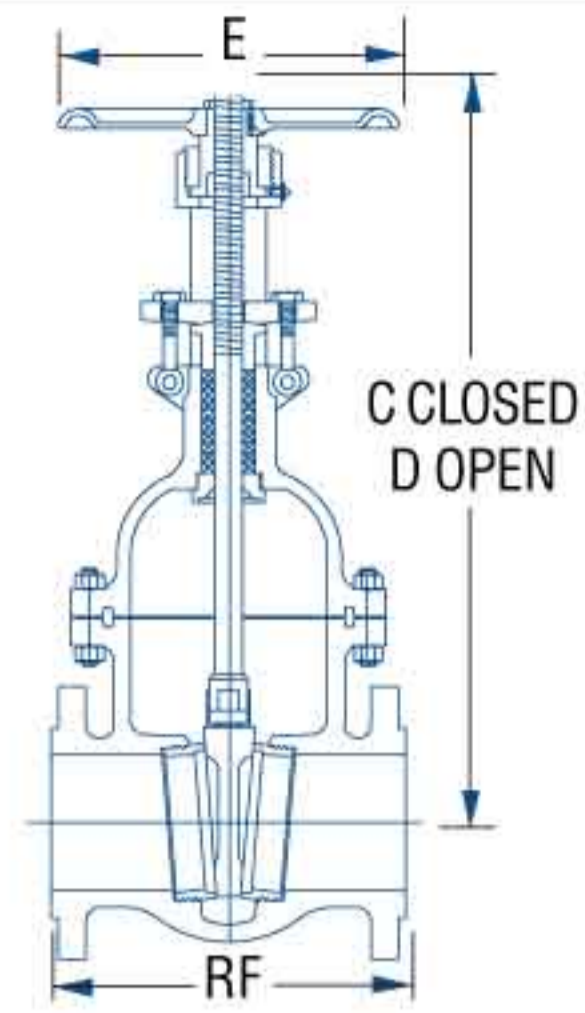

**VALVE DIMENSIONS AND WEIGHTS**

		2"	2.5"	3"	4"	6"	8"	10"	12"	
<b>600 LB.</b>	End to End <b>RF-BW</b>	11.5	13.0	14.0	17.0	22.0	26.0	31.0	33.0	
	End to End <b>RTJ</b>	11.625	13.125	14.125	17.125	22.125	26.125	31.125	33.125	
	<b>C- Closed</b>	18.3	17.6	23.2	27.0	32.1	41.4	42.8	49.1	
	<b>D- Open</b>	20.74	20.8	26.98	32.0	38.8	50.06	53.43	61.1	
	<b>E</b>	11.81	10.0	15.75	15.75	23.62	31.5	43.3	43.3	
	<b>WEIGHTS</b>									
	<b>RF</b>	97.00	105.8	178.6	299.8	648.1	1122	1673	2282	
	<b>BW</b>	79.37	85.98	156.6	246.9	540.0	965.4	1389	1993	
		<b>14"</b>	<b>16"</b>	<b>18"</b>	<b>20"</b>	<b>24"</b>	<b>30"</b>	<b>36"</b>	<b>42"</b>	
	End to End <b>RF-BW</b>	35.0	39.0	43.0	47.0	55.0	65.0	82.0	96.0	
End to End <b>RTJ</b>	35.125	39.125	43.125	47.25	55.375	65.5	82.625	-		
<b>C- Closed</b>	62.8	67.7	77.75	84.25	93.5	120.8	128.9	151.6		
<b>D- Open</b>	76.6	84.2	96.65	102.75	117.1	151.5	165.5	191.75		
<b>E</b>	78.7	78.7	78.7	78.7	78.7	36.0	36.0	36.0		
<b>WEIGHTS</b>	3175	3968	5952	6856	10158	17786	16358	22884		
<b>RF</b>	2838	3406	5309	6029	9128	-	14727	-		
	<b>3"</b>	<b>4"</b>	<b>6"</b>	<b>8"</b>	<b>10"</b>	<b>12"</b>	<b>14"</b>	<b>16"</b>		
<b>900 LB.</b>	End to End <b>RF-BW</b>	15.0	18.0	24.0	29.0	33.0	38.0	40.5	44.5	
	End to End <b>RTJ</b>	15.125	18.125	24.125	29.125	33.125	38.125	40.875	44.875	
	<b>C- Closed</b>	24.2	29.9	37.8	47.0	52.56	54.7	60.8	72.44	
	<b>D- Open</b>	27.94	34.62	44.69	55.66	62.79	66.9	73.8	87.99	
	<b>E</b>	15.75	19.7	31.5	43.3	43.3	78.7	78.7	78.7	
	<b>WEIGHTS</b>	257.7	454.1	914.9	1689	2315	3197	3695	5789	
	<b>RF</b>	220.4	396.8	776.0	1459	2006	2778	-	4841	
		<b>2"</b>	<b>2.5"</b>	<b>3"</b>	<b>4"</b>	<b>6"</b>	<b>8"</b>	<b>10"</b>	<b>12"</b>	
	<b>1500 LB.</b>	End to End <b>RF-BW</b>	14.5	16.5	18.5	21.5	27.75	32.75	39.0	44.5
		End to End <b>RTJ</b>	14.625	16.625	18.625	21.625	28.0	33.125	39.375	45.125
<b>C- Closed</b>		21.85	20.9	21.58	30.15	39.5	46.0	55.1	66.0	
<b>D- Open</b>		24.8	24.2	29.59	35.05	45.4	54.46	64.74	79.0	
<b>E</b>		15.75	14.0	19.7	23.62	31.5	43.3	78.7	78.7	
<b>WEIGHTS</b>		213.8	242.5	392.4	634.9	1523	2566	4078	5787	
<b>RF</b>		167.5	198.4	321.9	560.0	1296	2271	3505	5225	
		<b>2"</b>	<b>3"</b>	<b>4"</b>	<b>6"</b>	<b>8"</b>	<b>10"</b>	<b>12"</b>		
<b>2500 LB.</b>		End to End <b>RF-BW</b>	17.75	22.75	26.50	36.0	40.25	50.0	56.0	
		End to End <b>RTJ</b>	17.875	23.0	26.875	36.5	40.875	50.875	56.875	
	<b>C- Closed</b>	24.8	28.97	30.11	44.88	-	66.53	76.77		
	<b>D- Open</b>	27.47	32.71	33.92	51.17	-	74.99	85.62		
	<b>E</b>	15.74	31.49	31.49	43.30	-	-	-		
	<b>WEIGHTS</b>	399.0	736.3	1829	2833	-	-	-		
	<b>RF</b>	-	-	-	-	-	-	-		