

Overview	12
150 lb. valves	13
300 lb. valves	13
600 lb. valves	14
900 lb. valves	14
1500 lb. valves	14

GLOBE VALVES

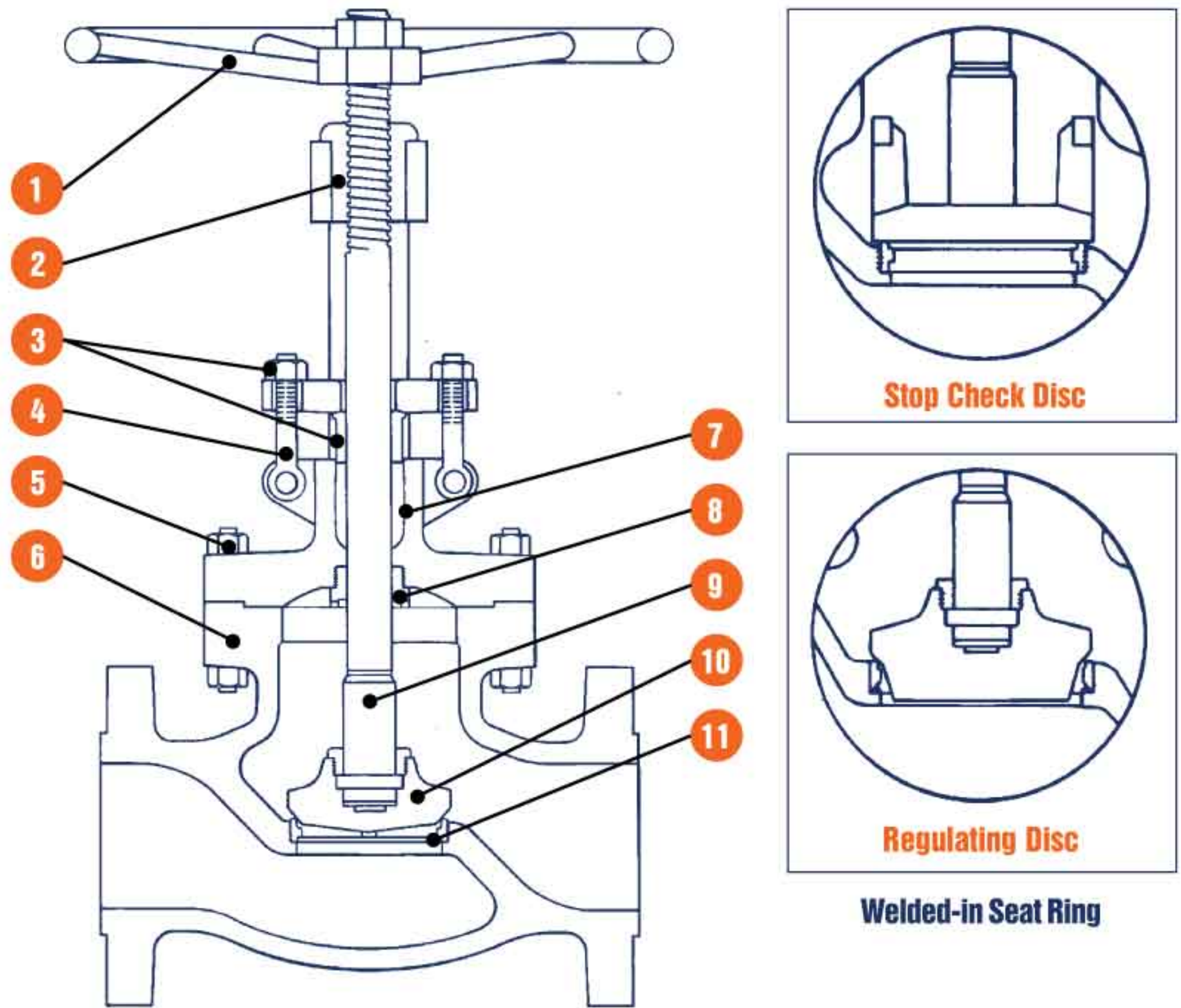

GLOBE VALVES

Cast steel, outside screw and yoke, rising stem, swivel plug disc.



1. **HANDWHEEL.** The five-spoked handwheel is fabricated from steel pipe. The hub has a square hole for coupling with the stem.
2. **YOKE SLEEVE.** The yoke sleeve is made of cast Iron Ni resist D2 having high resistance to wear and a high melting point, about 2000° F. It is screwed into the bonnet and properly sized to withstand the stresses which develop when opening and closing the valve.
3. **GLAND AND FLANGE.** They are forged steel and are supplied in two pieces. The contact surfaces between gland and gland flange have a spherical profile to permit the gland to descend parallel to the stem even if the eyebolts are unevenly tightened.
4. **GLAND BOLTS AND NUTS.** The forged steel gland bolts are of the eyebolt type which can be swung outward for ease of gland repacking. They are fixed to the bonnet by stud bolts and nuts.
5. **BONNET BOLTING.** Bonnet studs and nuts are manufactured from alloy steel to the relevant ASTM standard.
6. **BODY.** The body is in cast steel. The basic dimensions, i.e. wall thickness, face to face and flanges comply with the relevant ANSI standards. The body-to-bonnet flange is circular and the sealing surfaces for connection to the bonnet are recessed in the 150 and 300 lb. Series and ring joint in 600 lb. class and above. Bosses are provided for drain taps or by-pass piping.
7. **BONNET.** The bonnet is in cast steel. It is machined to accept the yoke sleeve and incorporates a stuffing box dimensioned in accordance with the API standard.
8. **BONNET BUSHING.** The bonnet bushing or backseat is in forged stainless steel and forms part of the trim. Special attention is given both to its machining and heat treatment.
9. **STEM.** The stem is in forged stainless steel and is part of the trim. A ground backseat is provided to ensure a perfectly tight seal to the stuffing box when the valve is fully open. The stem is attached to the disc by means of a threaded ring which allows the disc to rotate. The stem is ground to minimize friction and prevent damage to gland packing. The threading is trapezoidal ACME type.
10. **DISC.** The disc is part of the trim. It is in forged stainless steel for diameters up to 6" and in cast steel for larger valves. It is normally supplied of the flat, tapered or plug type or, on request, of the regulating type, always free to rotate on the stem. Special attention is given to the seating face which is ground and lapped.
11. **SEAT RING.** The ring is forged stainless steel and is part of the trim. They are seal welded in place. Special attention is given to the seating face which is ground and lapped, for a perfectly tight seal. Threaded-in seat ring may be supplied upon request.

150 LB.

300 LB.

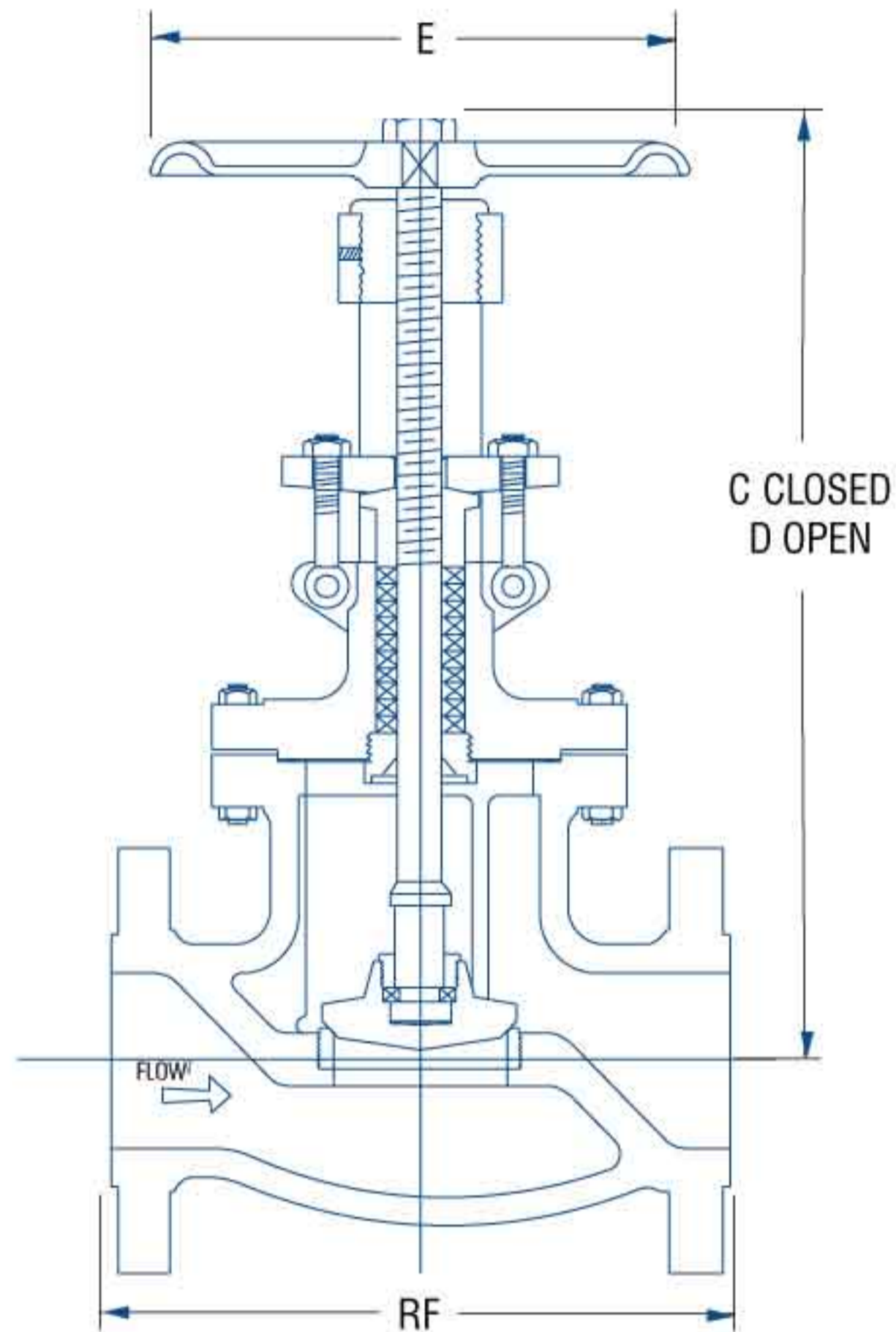

VALVE DIMENSIONS AND WEIGHTS

		2"	2.5"	3"	4"	6"	8"	10"	12"	14"	16"	18"	20"
150 LB.	End to End RF-BW	8.0	8.5	9.5	11.5	16.0	19.5	24.5	27.5	31.0	36.0	37.44	38.5
	C- Closed	15.18	15.3	17.2	20.51	22.5	25.88	28.03	35.62	33.38	48.58	52.7	45.58
	D- Open	16.16	16.378	18.77	22.16	24.67	29.67	32.79	40.81	38.73	57.32	60.2	57.32
	E	11.81	11.81	11.81	11.81	23.62	23.62	31.49	31.49	78.74	36.0	36.0	36.0
	WEIGHTS	RF	57.32	72.75	92.59	147.7	251.3	396.8	659.2	923.7	1184	1784	2344
	BW	46.30	59.29	72.75	112.4	216.0	357.1	593.0	862.0	1065	1583	2183	-
		2"	2.5"	3"	4"	6"	8"	10"	12"	14"	16"		
300 LB.	End to End RF-BW	10.5	11.5	12.5	14.0	17.5	22.0	24.5	28.0	34.0	36.0		
	End to End RTJ	11.125	12.125	13.125	14.625	18.125	22.625	25.125	28.625	34.625	36.625		
	C- Closed	15.15	15.3	18.81	21.77	24.05	27.08	33.42	45.98	43.85	57.87		
	D- Open	16.8	17.0	20.26	23.65	27.0	31.64	36.92	50.38	49.75	66.49		
	E	11.81	11.81	11.81	15.74	23.62	31.49	31.49	43.3	78.74	36.0		
WEIGHTS	RF	74.96	99.21	132.3	194.0	372.6	562.2	937.0	1510	1911	2465		
	BW	57.32	79.40	108.0	143.3	319.7	469.6	811.4	1343	1659	2150		

Materials and trim specifications Page 60
All dimensions are in inches, all weights are in pounds.

End to end dimensions are per ANSI/ASME B16.10
where applicable.

600 LB.

900 LB.

1500 LB.

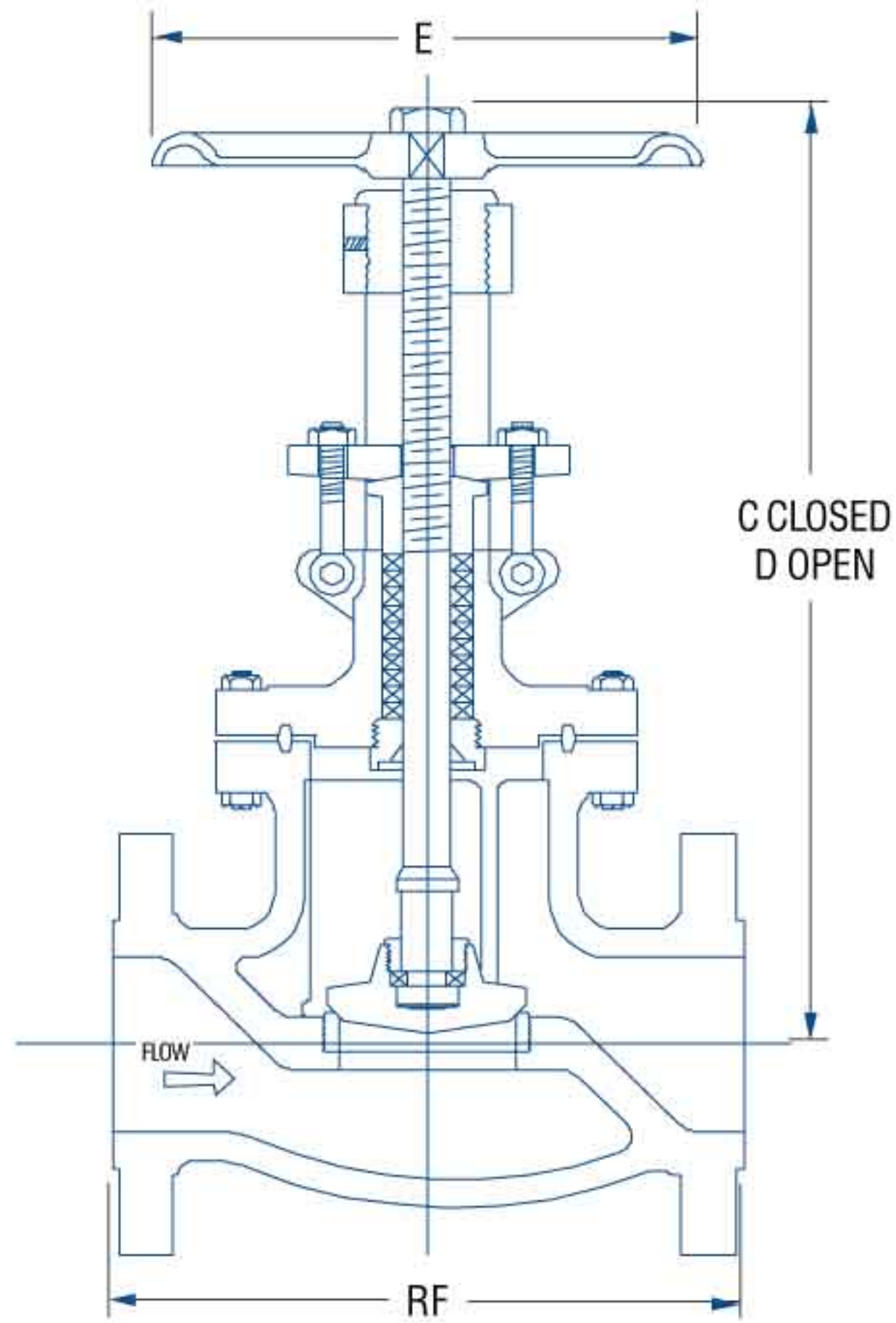

VALVE DIMENSIONS AND WEIGHTS

		2"	2.5"	3"	4"	6"	8"	10"	12"	14"	16"
600 LB.	End to End RF-BW	11.5	13.0	14.0	17.0	22.0	26.0	31.0	33.0	35.0	39.0
	End to End RTJ	11.625	13.125	14.125	17.125	22.125	26.125	31.125	33.125	35.125	39.125
	C- Closed	18.08	20.5	21.92	26.45	36.96	42.50	48.98	60.55	60.55	68.57
	D- Open	18.98	21.65	23.92	29.42	40.18	46.90	54.12	66.14	66.14	74.94
	E	11.81	15.74	15.74	23.62	31.49	43.3	43.3	43.3	36.0	36.0
	WEIGHTS	RF	101.4	134.5	180.8	317.5	698.9	1212	1940	2645	3307
	BW	83.77	112.4	152.1	273.4	579.9	1089	1686	2283	2965	-
		3"	4"	6"	8"	10"	12"				
900 LB.	End to End RF-BW	15.0	18.0	24.0	29.0	33.0	38.0				
	End to End RTJ	15.125	18.125	24.125	29.125	33.125	38.125				
	C- Closed	26.10	29.44	43.85	48.03	56.61	63.70				
	D- Open	28.24	33.21	47.78	53.1	63.3	70.84				
	E	23.62	23.62	31.5	43.3	78.74	53.15				
	WEIGHTS	RF	264.5	476.2	1146	1817	2976	3748			
	BW	229.3	432.1	1023	1696	2747	3439				
		2"	2.5"	3"	4"	6"	8"	10"			
1500 LB.	End to End RF-BW	14.5	16.5	18.5	21.5	27.75	32.75	39.0			
	End to End RTJ	14.625	16.625	18.625	21.625	28.0	33.125	39.375			
	C- Closed	22.15	25.8	27.44	32.16	47.44	59.05	65.7			
	D- Open	24.35	27.5	31.06	36.01	50.58	65.03	69.7			
	E	23.62	18.0	31.49	31.49	78.74	78.74	36.0			
	WEIGHTS	RF	211.6	295.4	414.5	676.8	1808	2425	3946		
	BW	180.7	233.7	352.8	590.8	1621	2099	3395			

Materials and trim specifications Page 60
All dimensions are in inches, all weights are in pounds.

End to end dimensions are per ANSI/ASME B16.10 where applicable.